

Разделители транспортных средств ESCC

Технические характеристики

По вопросам продаж и поддержки обращайтесь:

Алматы (727)345-47-04
Ангарск (3955)60-70-56
Архангельск (8182)63-90-72
Астрахань (8512)99-46-04
Барнаул (3852)73-04-60
Белгород (4722)40-23-64
Благовещенск (4162)22-76-07
Брянск (4832)59-03-52
Владивосток (423)249-28-31
Владикавказ (8672)28-90-48
Владимир (4922)49-43-18
Волгоград (844)278-03-48
Вологда (8172)26-41-59
Воронеж (473)204-51-73
Екатеринбург (343)384-55-89

Иваново (4932)77-34-06
Ижевск (3412)26-03-58
Иркутск (395)279-98-46
Казань (843)206-01-48
Калининград (4012)72-03-81
Калуга (4842)92-23-67
Кемерово (3842)65-04-62
Киров (8332)68-02-04
Коломна (4966)23-41-49
Кострома (4942)77-07-48
Краснодар (861)203-40-90
Красноярск (391)204-63-61
Курск (4712)77-13-04
Курган (3522)50-90-47
Липецк (4742)52-20-81

Магнитогорск (3519)55-03-13
Москва (495)268-04-70
Мурманск (8152)59-64-93
Набережные Челны (8552)20-53-41
Нижний Новгород (831)429-08-12
Новокузнецк (3843)20-46-81
Ноябрьск (3496)41-32-12
Новосибирск (383)227-86-73
Омск (3812)21-46-40
Орел (4862)44-53-42
Оренбург (3532)37-68-04
Пенза (8412)22-31-16
Петрозаводск (8142)55-98-37
Псков (8112)59-10-37
Пермь (342)205-81-47

Ростов-на-Дону (863)308-18-15
Рязань (4912)46-61-64
Самара (846)206-03-16
Санкт-Петербург (812)309-46-40
Саратов (845)249-38-78
Севастополь (8692)22-31-93
Саранск (8342)22-96-24
Симферополь (3652)67-13-56
Смоленск (4812)29-41-54
Сочи (862)225-72-31
Ставрополь (8652)20-65-13
Сургут (3462)77-98-35
Сыктывкар (8212)25-95-17
Тамбов (4752)50-40-97
Тверь (4822)63-31-35

Тольятти (8482)63-91-07
Томск (3822)98-41-53
Тула (4872)33-79-87
Тюмень (3452)66-21-18
Ульяновск (8422)24-23-59
Улан-Удэ (3012)59-97-51
Уфа (347)229-48-12
Хабаровск (4212)92-98-04
Чебоксары (8352)28-53-07
Челябинск (351)202-03-61
Череповец (8202)49-02-64
Чита (3022)38-34-83
Якутск (4112)23-90-97
Ярославль (4852)69-52-93

Россия +7(495)268-04-70

Казахстан +(727)345-47-04

Беларусь +(375)257-127-884

Узбекистан +998(71)205-18-59

Киргизия +996(312)96-26-47

эл.почта: ehw@nt-rt.ru || сайт: <https://espetech.nt-rt.ru>

ESCC series

Vehicle separation curtain

ESCC series is a kind of safety light curtain specially design for highway, toll collection by weight, highway detection station, customs or other vehicle detection site. Which is mainly achieve function of vehicle height limit, vehicle separation, detection of vehicle speed and vehicle driving direction, etc. Stainless steel or cold rolled steel plate enclosure for ESCC is built in heating glass, temperature & humidity controller, realize automatic heating when the humidity is too high or temperature is too low. To ensure the curtain can be used in wet areas, rain and snow weather.

Product feature

- Specially designed for vehicle separation detection.
- High energy and penetration rate imported photocell is used to keep stable and reliable performance. It's easy to install and align, When used for 4.5m lane, the excess gain value can reach 5 times. Well work even though harsh environment with dust, rain, fog, special temperature.
- NPN or PNP signal output vehicle detection signal and fault detection signal
- With high self-inspection function, it can send alarm in time when monitoring objects blocked beam, and automatically shield abnormal beam to ensure curtain can work continually until the exception is cleared and restored.
- Rs485 or RS232 signal can detect the status of blocked beams.
- It can communicate with host computer and support secondary development.
- Unique program calculation can set according to the requirement that effective signal output until blocked beam object reach specified size.
- Industrial ambient temperature: -40-55°C, the maximum relative humidity 95% (50°C), protection rate IP67, can be used in high cold and hot area stably.
- The enclosure can adjust temperature automatically.

Safety Light Curtain Output Setting

- Only when more than 6 consecutive beams are blocked at the same time (such as when the head enters the detection area), NPN OSSD1 becomes high level to generate signal output, and output 1 remains active until all beams are switched on. The purpose of the setup is to reliably detect the trailer hook, and eliminate the interference of birds, stones, hands and other external factors.
- When a beam or several beams of light are continuously blocked for more than 3 minutes, the system will automatically screen the beam and ensure that the vehicle can still be normally detected. After that, NPN output 2(alarm) will be activated to remind the staff to remove the alarm source. The reasons for the long time blocking of the beam may include mud, insects stuck to the glass window, and the failure of the photocell itself. After the cause of the failure is eliminated, the system automatically removes the shielding function immediately, and the alarm output is removed at the same time. Factory Settings can block up to 6 beams of light.



Technical Parameter

Parameter of safety light curtain

Working Power Supply	DC24V±15%
Beam space	20mm/40mm
Resolution	25mm/45mm
Beams	20mm beam space: 32, 64 40mm beam space: 16, 32
Wave Length	940nm
Capacity	<5W
Sensing distance	max. 20m (Remark: if light reflection, please let us know in advanced)
Anti-light interference	100000 Lux (incidence Angle > 5)
Sensing method	Thru-beam type
Output Mode	NPN, PNP, RS485
Type Of Output (OSSD)	NPN/ PNP semiconductors, current <200mA, residual voltage: 1V max. Leakage current: 1mA (except voltage influenced by lengthen cable) RS485 output: Modbus communication protocol, customized protocol.
Protective Circuit	power supply overvoltage protection, reverse polarity protection and output overcurrent protection
Output Signal	OSSD1 output blocking signal, OSSD2 output abnormal signal
The Emission Indicator	normal:The indicator is steady green
The Receiving Indicator	Normal: The green light is steady on Abnormal alignment : The indicator is steady red CP malfunction: Red & green light blink alternately.
Insulation Resistance	>100MΩ
Ambient Operating Temperature	-40°C to 55°C
Storage Temperature	-55°C to 80°C
Ambient Humidity	When the temperature is 20° C, the relative air humidity is less than 85%
Enclosure rating	IP65
Section Size	35*50mm

Electrical parameters of the protective cover

Operating Voltage	24V±10%
Working Current	10A
Humidity Switch	Mechanical nylon film trigger switch relative temperature 20%-80%
Main Control Unit	When the heating unit of the starts, the red LED light at the front will glow
Cover Structure	Stainless Steel (201/304)
Cover	self-adjusting heating glass
Heating Glass	Core 2 No. 14 standard cable with ground cable is required for heating glass (cable not provided)
Door Opening Method	Front-door opening mode
Door Closing Method	Front-door screws fixed

Grating Model Description (for example: ESCC6420RH1N-20)

ESCC	64	20	RH1	N	—	20
▼	▼	▼	▼	▼		▼
Model	Beams	Beam space	Bracket	Output signal		Sensing distance
ESCCseries	16,32,64	20mm 40mm	RH1: CRH-201-1000(Outer cover) RH2: CRH-304-1000(Outer cover) RH3: CRH-201-1650(Outer cover) RH4: CRH-304-1650(Outer cover) L1 side mounting bracket	N: NPN P: PNP RY: RS485 active mode RZ: RS485 passive mode		20: 0.1~20M

Wire connection

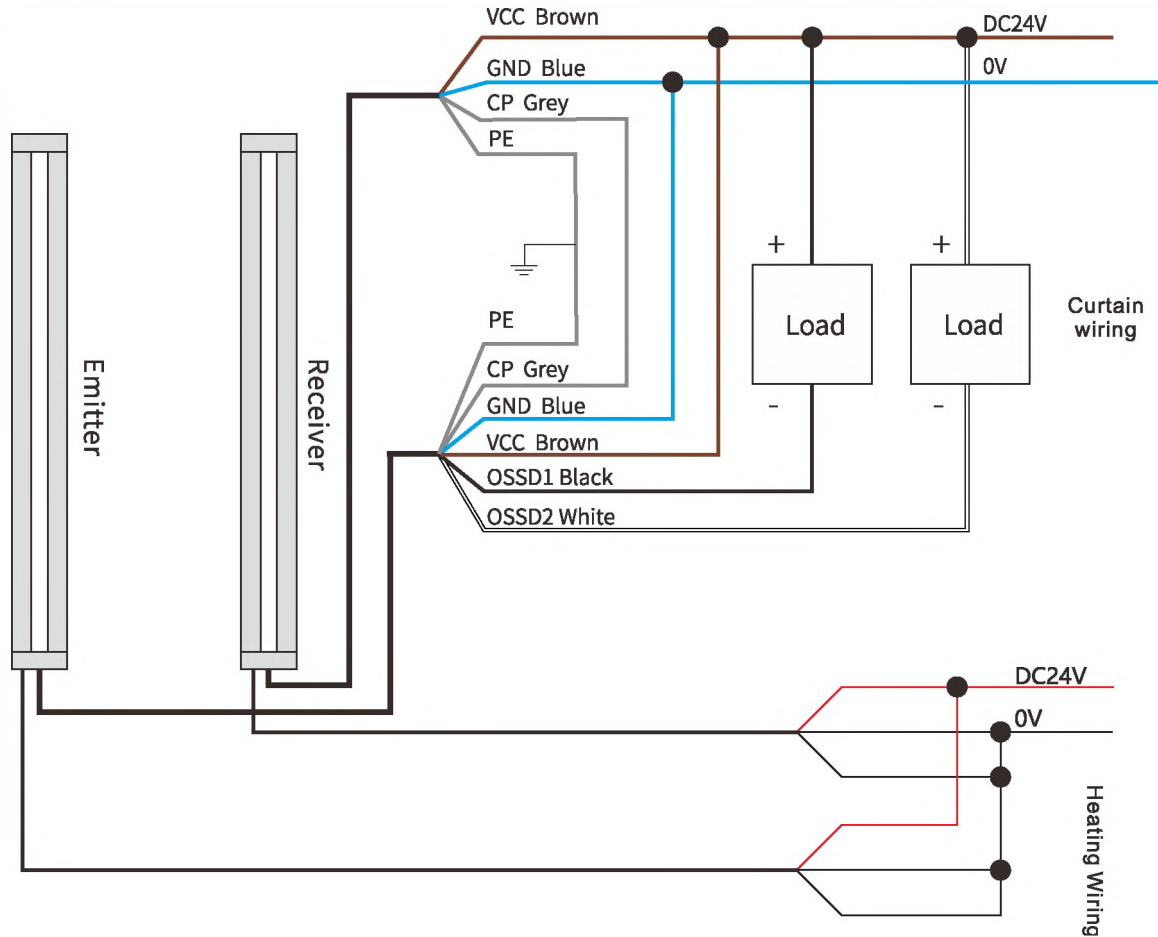

Safety light curtain output setting

- Transmitter brown line VCC and receiver brown line VCC phase, and then connected to the positive DC12~30V power supply.
- Connect the blue wire GND of the transmitter to the blue wire GND of the receiver, and then connect to the negative 0V of the power supply.
- The transmitter gray line CP is connected to the receiver gray line CP.
- The output signal of the receiver black line OSSD1 is 0V, which outputs the vehicle detection signal.
- Receiver white line OSSD2 output signal is 0V, output light curtain fault alarm signal.
- Receiver green wire 485A+ connects to system 485 communication port A (additional configuration).
- Receiver Yellow Wire 485B- Connects to system 485 communication port B (additional configuration).

Installation instructions of protective cover wiring

- With practical applications in mind. At present, the humidity control switch is set to 60%-70%. When testing the circuit, turn the knob clockwise to the sound of "ka-thien" and the humidity switch is on. After the test, please turn counterclockwise to the humidity required by your company or our factory settings.
- In the case of DC power supply, pay attention to the positive and negative connection between the wire and the power supply. Red wire connected to the positive side of the power supply: Two colored wires must be connected together to the negative side of the power supply. If the AC 24V power supply is used. The red is connected to one pole, and the other two wires are connected to one pole.

ESCC selection sheet

● Beam space 20mm, resolution is 25mm

Beams (n)	Protective height (mm)	Total height (mm)	Model	Enclosure	Material
32	620	705	ESCC3220	CRH-201-1000	201 Stainless steel
				CRH-304-1000	304 Stainless steel
64	1260	1345	ESCC6420	CRH-201-1650	201 Stainless steel
				CRH-304-1650	304 Stainless steel

● Beam space 40mm, resolution is 45mm

Beams (n)	Protective height (mm)	Total height (mm)	Model	Enclosure	Material
16	600	685	ESCC1640	CRH-201-1000	201 Stainless steel
				CRH-304-1000	304 Stainless steel
32	1240	1325	ESCC3240	CRH-201-1650	201 Stainless steel
				CRH-304-1650	304 Stainless steel

Besides above model, the safety light curtain can be customized according to customer requirements.

Fault Detection and Removal

Fault Symptom	Possible Cause	Solution to the Fault
The light curtain does not work, and all indicators are off.	No power supply voltage.	Check the power supply and the wiring
Light curtain intermittently work, The indicator light is on and off	The cable connection is in poor contact	Fastening control cable
	The Light curtain doesn't work well	Readjust to make it work normally
	Poor grounding or interference with the ground line	To ground or remove interference reliably
	The luminous surface of the emitter and the light receiver is shielded by foreign bodies.	Clean the luminous surface
The receiver's red and green indicators blink at the same time.	the CP synchronization cable is out of sync	Check whether the CP synchronization cable is properly connected
The heating glass has been dry heating state	Mixing control switch to the lower humidity scale	Adjust the humidity control to 60%-70%
Heating glass cannot be heated	The control range of the mixing switch is too high.	Adjust the mixing switch to 60%-70%

eams	Protective height (mm)	Total height (mm)	Model	Enclosure	Material
32	620	705	ESCC3220	CRH-201-1000 CRH-304-1000	201 Stainless steel 304 Stainless steel
64	1260	1345	ESCC6420	CRH-201-1650 CRH-304-1650	201 Stainless steel 304 Stainless steel

eams	Protective height (mm)	Total height (mm)	Model	Enclosure	Material
16	600	685	ESCC1640	CRH-201-1000 CRH-304-1000	201 Stainless steel 304 Stainless steel
32	1240	1325	ESCC3240	CRH-201-1650 CRH-304-1650	201 Stainless steel 304 Stainless steel

По вопросам продаж и поддержки обращайтесь:

Алматы (727)345-47-04
Ангарск (3955)60-70-56
Архангельск (8182)63-90-72
Астрахань (8512)99-46-04
Барнаул (3852)73-04-60
Белгород (4722)40-23-64
Благовещенск (4162)22-76-07
Брянск (4832)59-03-52
Владивосток (423)249-28-31
Владикавказ (8672)28-90-48
Владимир (4922)49-43-18
Волгоград (844)278-03-48
Вологда (8172)26-41-59
Воронеж (473)204-51-73
Екатеринбург (343)384-55-89

Иваново (4932)77-34-06
Ижевск (3412)26-03-58
Иркутск (395)279-98-46
Казань (843)206-01-48
Калининград (4012)72-03-81
Калуга (4842)92-23-67
Кемерово (3842)65-04-62
Киров (8332)68-02-04
Коломна (4966)23-41-49
Кострома (4942)77-07-48
Краснодар (861)203-40-90
Красноярск (391)204-63-61
Курск (4712)77-13-04
Курган (3522)50-90-47
Липецк (4742)52-20-81

Магнитогорск (3519)55-03-13
Москва (495)268-04-70
Мурманск (8152)59-64-93
Набережные Челны (8552)20-53-41
Новокузнецк (3843)20-46-81
Ноябрьск (3496)41-32-12
Новосибирск (383)227-86-73
Омск (3812)21-46-40
Орел (4862)44-53-42
Оренбург (3532)37-68-04
Пенза (8412)22-31-16
Петрозаводск (8142)55-98-37
Псков (8112)59-10-37
Пермь (342)205-81-47

Ростов-на-Дону (863)308-18-15
Рязань (4912)46-61-64
Самара (846)206-03-16
Санкт-Петербург (812)309-46-40
Саратов (845)249-38-78
Севастополь (8692)22-31-93
Саранск (8342)22-96-24
Симферополь (3652)67-13-56
Смоленск (4812)29-41-54
Сочи (862)225-72-31
Ставрополь (8652)20-65-13
Сургут (3462)77-98-35
Сыктывкар (8212)25-95-17
Тамбов (4752)50-40-97
Тверь (4822)63-31-35

Тольятти (8482)63-91-07
Томск (3822)98-41-53
Тула (4872)33-79-87
Тюмень (3452)66-21-18
Ульяновск (8422)24-23-59
Улан-Удэ (3012)59-97-51
Уфа (347)229-48-12
Хабаровск (4212)92-98-04
Чебоксары (8352)28-53-07
Челябинск (351)202-03-61
Череповец (8202)49-02-64
Чита (3022)38-34-83
Якутск (4112)23-90-97
Ярославль (4852)69-52-93

Россия +7(495)268-04-70

Казахстан +(727)345-47-04

Беларусь +(375)257-127-884

Узбекистан +998(71)205-18-59

Киргизия +996(312)96-26-47

эл.почта: ehw@nt-rt.ru || сайт: <https://espetech.nt-rt.ru>